



Anybus Wireless Bolt product

Base Protector and mounting kit for Anybus Wireless Bolt

The Bolt Base Protector offers the Bolt an all-around IP66/67 protection. This is ideal for outdoor usage or where the conditions are harsh and demanding.

The kit comes in two versions:

1. Base Protector only. This requires a flat surface with a 50,5 mm hole where the Bolt and Base Protector can be mounted.
2. Base Protector including a stainless-steel mounting bracket kit for wall or pole mounting.



Features & Benefits

- Offers all around IP66/67 protection for Anybus Wireless Bolt
- Durable and robust materials for outdoor usage
- Mounting Bracket kit offers wall or pole mounting option

Key Use Cases

- Optimal mounting of Anybus Wireless Bolt for good radio signal
- Wall or Pole mounting with the Mount Bracket kit

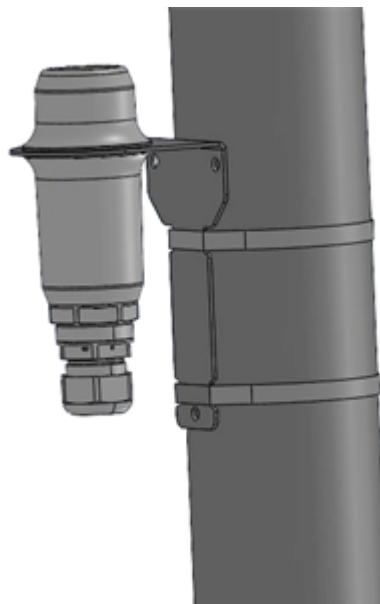

Bolt Base Protector with Mounting Bracket and slim clamps mounted on a pole



Mounting bracket

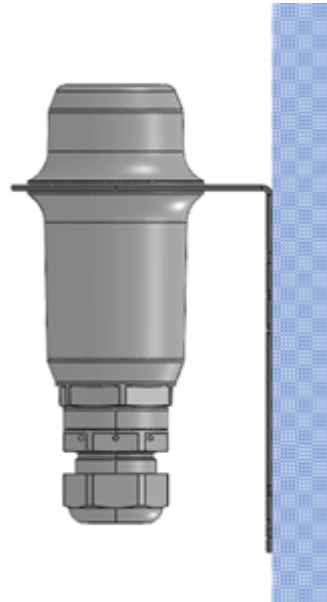

Bolt Base Protector with Mounting Bracket mounted on a wall.

Technical Specifications

Weight per Piece (excluding packing)	Base Protector: 90 g Base Protector and Mount Bracket kit: 440 g
Materials	Base Protector: NCSS1002-B PBT Valox 357x-7001 (F1). Suitable for outdoor use with respect to exposure to ultraviolet light, water exposure and immersion in accordance with UL 476C. Mount Bracket kit, Slim Clamps and screws: Stainless Steel Screw Anchors: Nylon Cable Gland: PC
Measurements	Base Protector: Height (excluding Cable Gland): 90 mm, Diameter (max): 67.6 mm Mount Bracket: Height 150 mm, Width 80 mm, Depth 100mm, 3x screw holes Ø 5.2 mm Screws: Ø 4.8 x 38 mm

Slim Clamps	Slim clamps for a pole diameter of 50-165 mm Width: 9 mm
Cable Gland	Base Protector Cable Gland: M32, rubber seal with 2 cable holes for \varnothing 6 mm \pm 0.1 mm, one cable rubber blind plug: \varnothing 6 mm, o-ring: M32x2,5
Screw Anchors	For 8 mm drill hole. Length 40 mm

Ordering information

Order Code	024708 - Base Protector 024709 - Base Protector and Mounting Bracket kit
Included components	024708: Base Protector, \varnothing 50mm O-ring, M32 Cable Gland with washer and rubber inserts, Installation Guide. 024709: Base Protector, \varnothing 50mm O-ring, M32 Cable Gland with washer and rubber inserts, mounting bracket, 3x screws, 3x screw anchors, 2x slim clamps, Installation Guide.

3 year guarantee. For purchasing instructions and terms and conditions, see: How to buy

Copyright © 2020 HMS Industrial Networks - All rights reserved.